

# KS SKEG CONTROL UNIT 4

SKEG CONTROL UNIT FOR KAJAK SPORT ROPE DEPLOYED SKEG SYSTEM 4



# SKEG CONTROL UNIT 4, PART LIST

## Parts

### 521410 Skeg control unit 4.

1. (521411) KS-skeg control 4. box
2. (521413) KS-skeg control 4. rail
3. (521415) KS-skeg control 4. plug x 2
4. (521417) KS-skeg control 4. button, male/female
5. (521419) KS-skeg control 4. spring for button
6. (521511) KS-tube connector male
7. (521513) KS-tube connector female
8. (521515) KS-tube connector spring, 0,1 Aisi 316
9. (490610) O-ring 10,0/3,0
10. (445510) Torx screw, countersunk, M5-10, A4, DIN 965 x 2
11. (433320) Torx screw, pan head M3-20, T-10, DIN 7985 x 2
12. Nut M3, A4, DIN 934 x 2

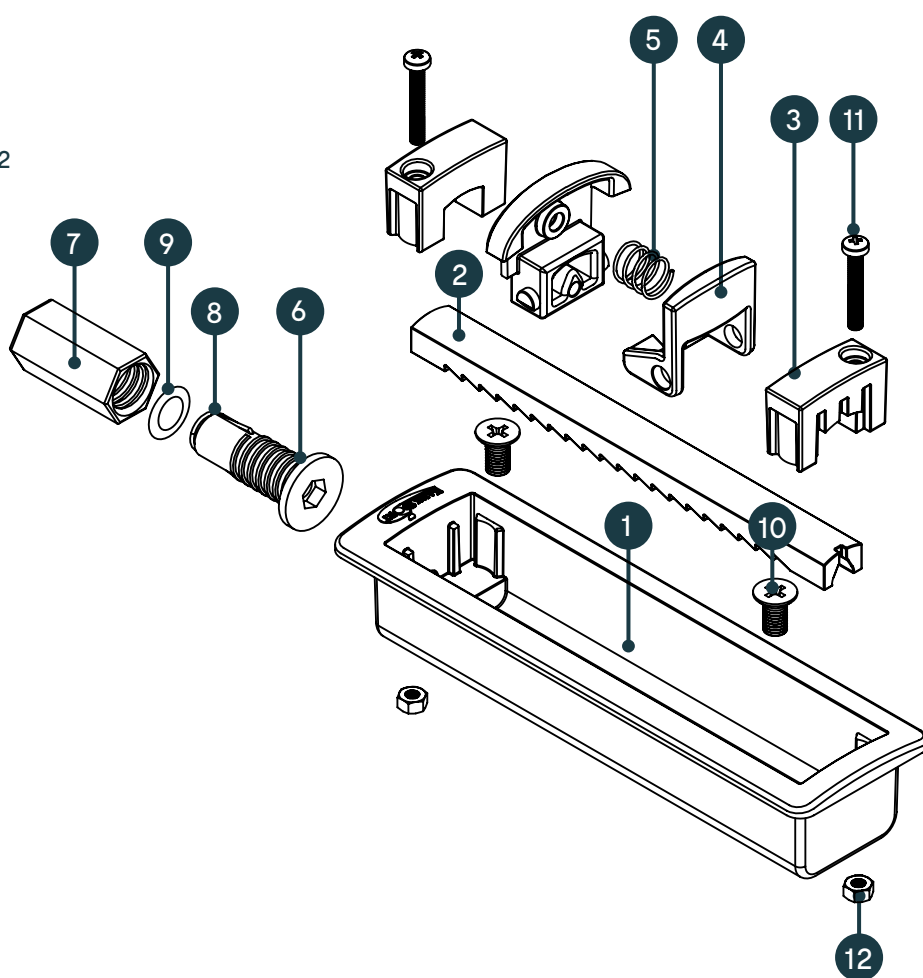

## SKEG CONTROL UNIT 4 MAIN DIMENSIONS

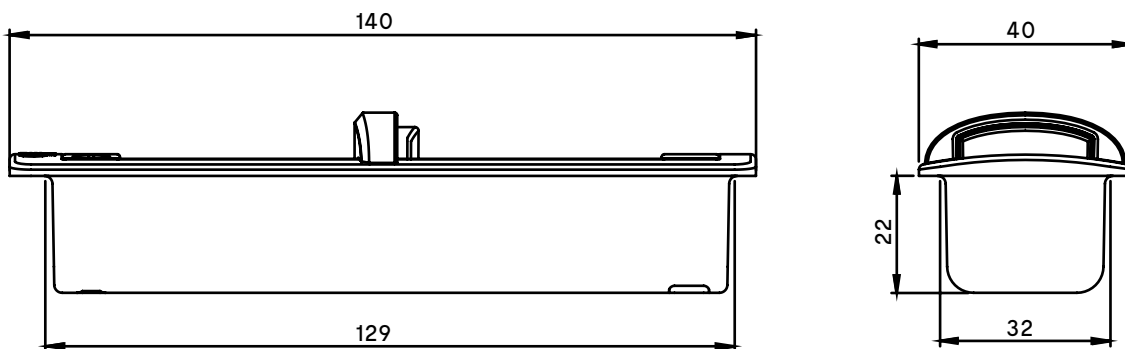

## DESIGN INSTRUCTIONS

### Placing the KS-Skeg control unit 4

It is important to pay attention to find optimal place for the skeg control unit when designing the kayak. z

Skeg control unit should be placed close to the paddler to have easy access on it at all times. It should not stick in the way when doing normal paddling rotation. Most often the optimal location is little bit forward from hip, next to the cockpit rim. If it's too far in the front the paddler can accidentally hurt his hand in it while paddling or it can disturb normal thigh support. If the unit is too much in side and close to the seam it will become the outmost part of the kayak in sideways. It is a risky location when storing and transporting the kayak.

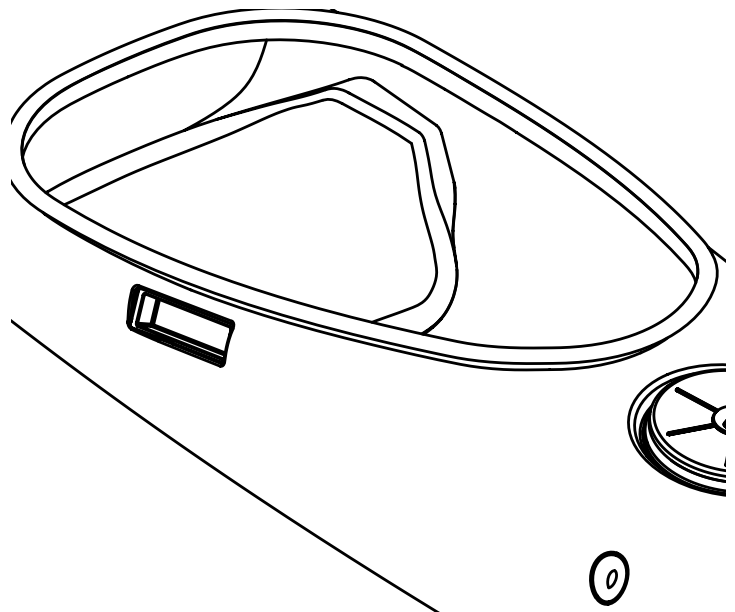

## Recessing the Skeg control unit in to the deck

1. Integrated premade deck recess for Skeg control unit (recommended assembly for plastic kayaks)  
- Closed and watertight deck feature offering a quick 1-2 insert screw installation.

2. Surface recessed open assembly, requires optional (521710) KS-adapter box for skeg control 4 (recommended assembly for composite kayaks)  
- Watertight and secure installation with dismantle option. Quick 2 screw assembly with watertight rubber sealing

3. Non recessed top surface assembly, requires optional (521710) KS-adapter box for skeg control 4 (recommended assembly for retrofitting)  
- Watertight and secure installation with dismantle option. Quick 2 screw assembly with watertight rubber sealing

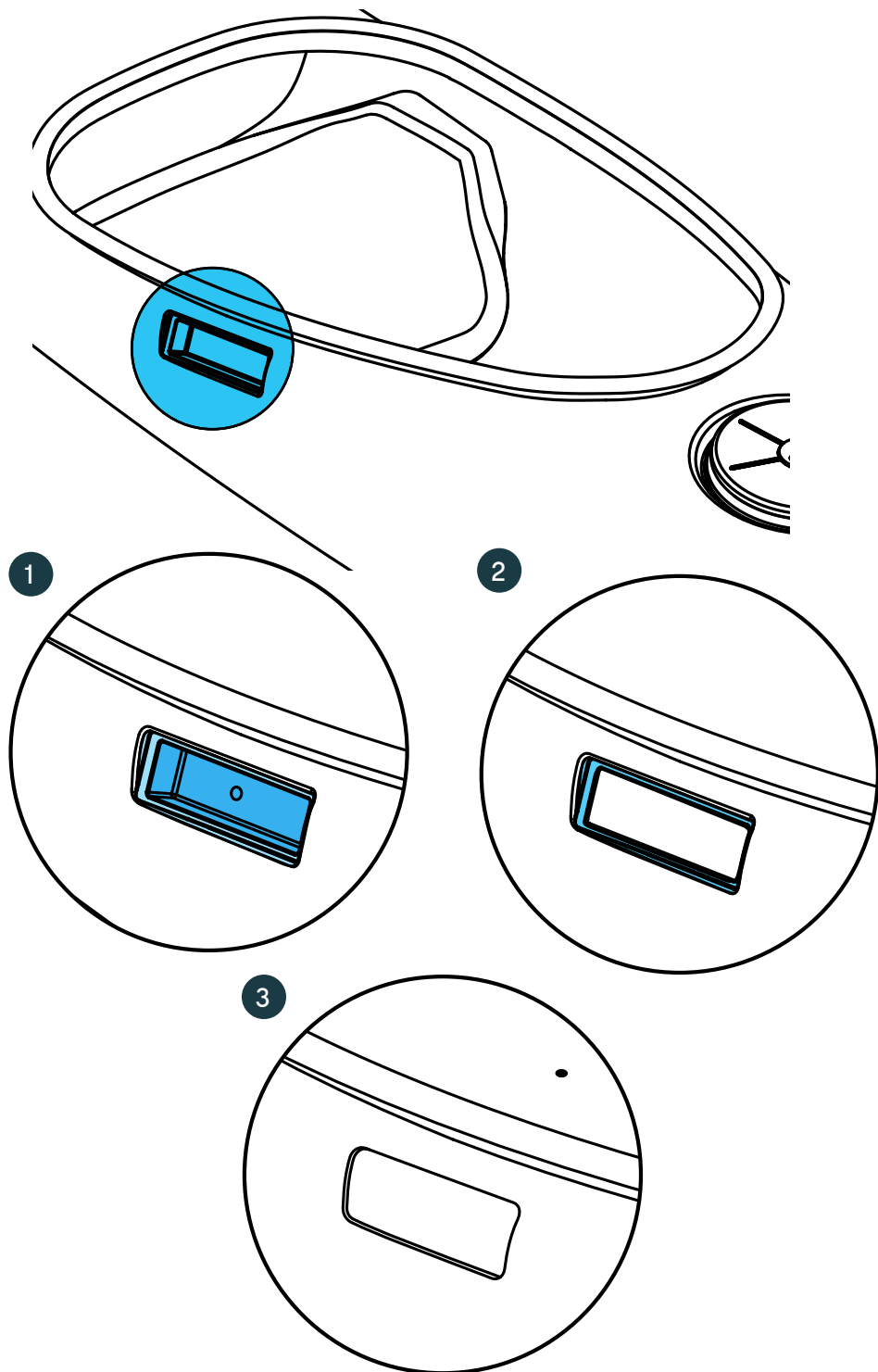

# KS-ADAPTER BOX FOR SKEG CONTROL UNIT 4, PART LIST

## Parts

### 521710 KS-adapter box for skeg control 4

1. (521711) KS-adapter box for control 4
2. (521 712) KS-Adapter box gasket
3. (461150) Nut M5, A4, DIN 934 x 2
4. (465150) Washer M5, A4, DIN 9021 x 2
5. (490600) O-ring (4,47 x 1,78) x 2

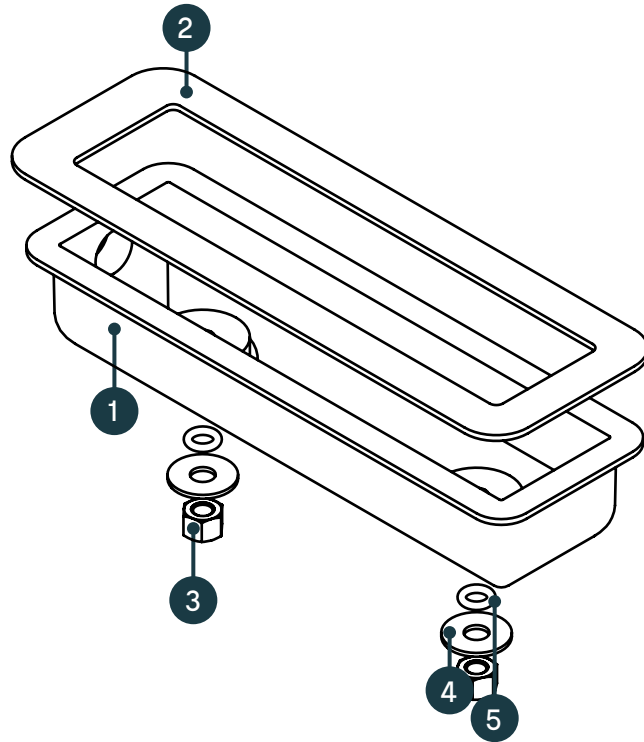

## INSTALLING THE SKEG CONTROL UNIT 4

### A. Installing the skeg control 4. box and KS-tube connector for premade deck recess

When kayak has a premade deck recess for skeg control unit. The assembly is started from mounting the KS-tube connector. KS-tube connector requires  $\varnothing 11$  mm hole in the aft end of the control unit recess. Push tube connector female part all the way in to the end and make sure the O-ring is left outside of the hull to ensure proper sealing for the inlet. Push the PA-tube inside in the male part, it will go in around 27 mm and seal itself against the male part. Push female part around the male part. Screw male and female parts firmly together to secure and seal the complete inlet.

Skeg control box has 3 mounting screw holes. In premade deck recess one or two screws will be enough for secure installation. Ready-made nut inserts are the quickest way to connect it. Place the skeg control box inside in the recess and secure from the bottom with screws that are included.

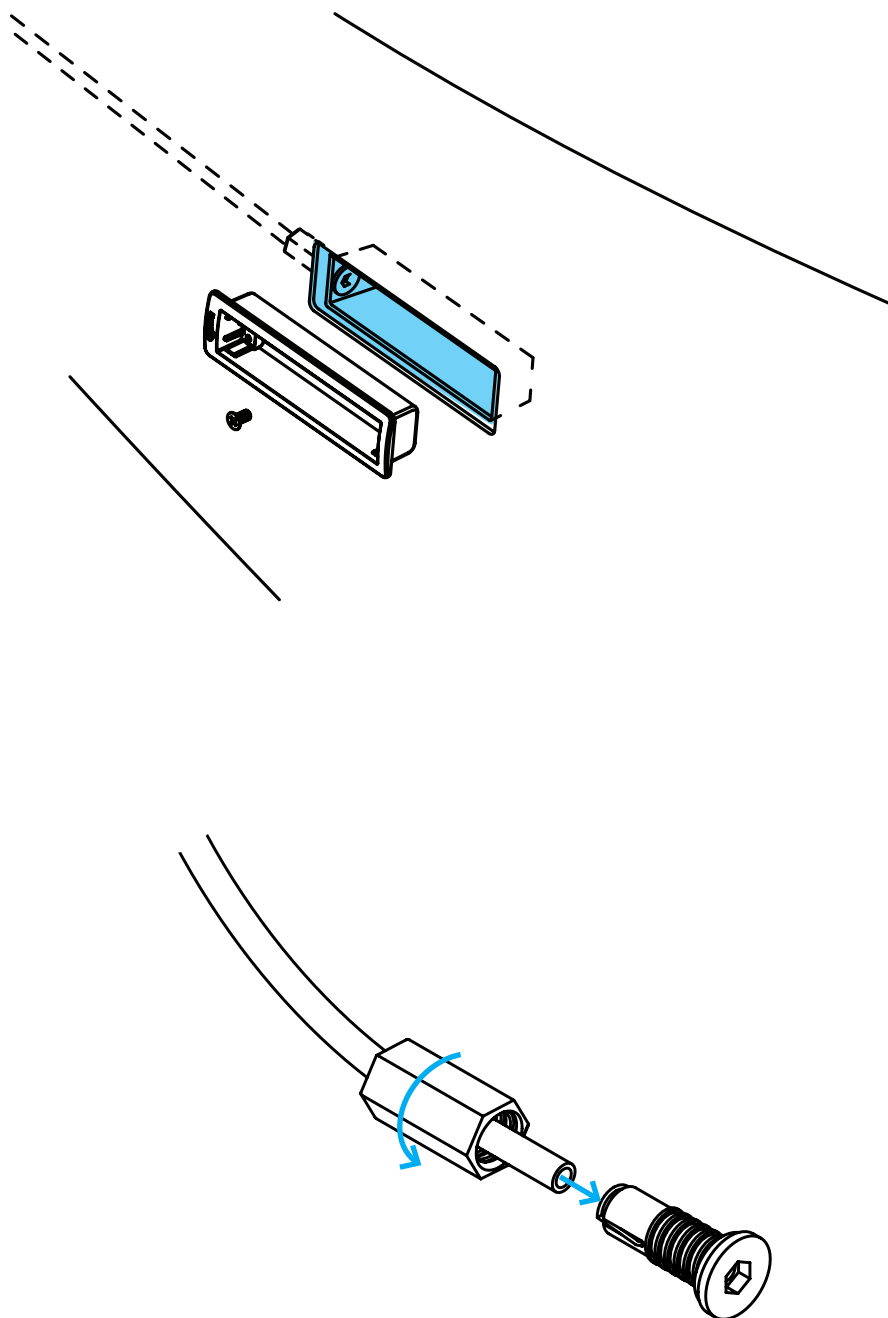

**B. Installing the skeg control 4 box and connector tube in the open surface recess or retrofit without any recess by using the KS-adapter box for skeg control 4.**

If having a surface recess in the deck without integrated closed box (composite kayaks) skeg control box can be installed by using optional KS-adapter box for skeg control 4. Adapter box has rubber sealing to ensure the connection. Screw connection allows firm tightening and enables later dismantle. Adapter box also has a place for tube connector to make the connection water tight. Please check tube connector installation from above in section 1.

Skeg control 4 box fits in to the recess from outside of the kayak. Adapter box and sealing connects the control box from inside of the kayak. These two components are fixed together with 2 screws, O-rings, washers and nuts that are included. Tighten the screws firmly to make the connection water tight.

When skeg control box is connected to the deck it is most easy to string the skeg rope inside in the tube already in this stage before continuing assembly.

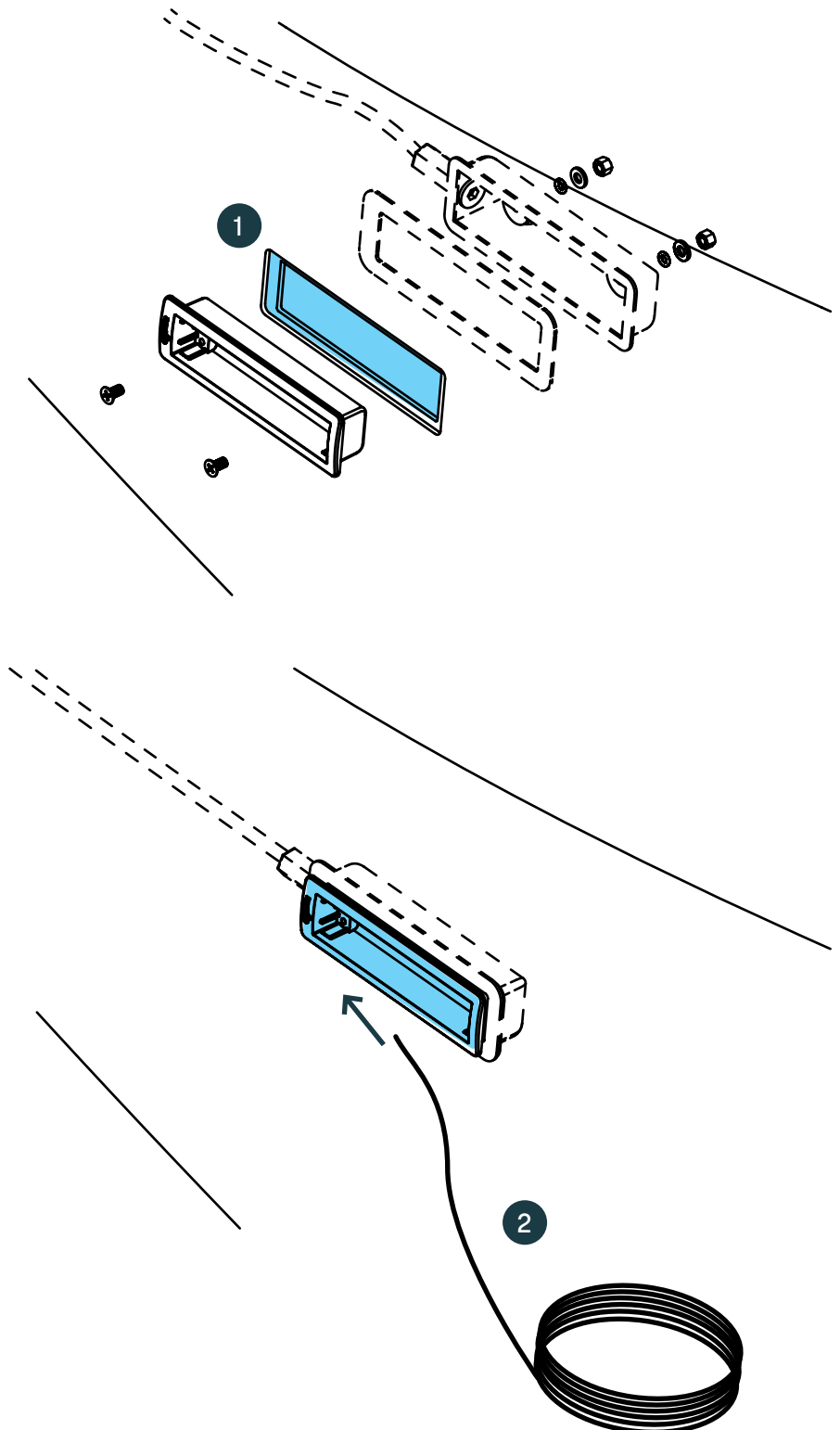

---

### Finish the skeg control unit assembly

1. String the rope in to the control button and secure with knot
2. Slide the Rail inside in the control button.
3. Please notice that the **Rail has small assembly hole** in front of it to make sure it can only be fitted correct way in to the control box.
4. Place the control button and rail package in to the control box (**rail assembly hole in front**)
5. Secure the rail with two plugs in both ends. Control box has integrated nuts where plug screws will attach.

